

AR400

OPERATING WEIGHT
4,550 - 5,000 kg

ENGINE OUTPUT
46 kW (61.5 HP)

SHOVEL CAPACITY
0.85 - 1.6 m³



 **weycor**
BY ATLAS WEYHAUSEN



FIRST IMPRESSIONS COUNT!

weycor wheel loaders are more than the sum of their parts. They reflect true passion, a fascination with technology and 'Made in Germany' quality. It's thanks to the innovative spirit of our people, their dedication to detail and their passion for powerful engine technology that this new generation of wheel loaders has been developed.

4.550 / 4.850* ^{KG}
OPERATING WEIGHT

46 ^{KW (61.5 HP)}
ENGINE OUTPUT

0.85 ^{M³}
SHOVEL CAPACITY

Operating data

Shovel capacity	0.85 m³
Track width	1,460 mm
Turning radius (outer shovel edge)	4,170 mm
Tear out force	5,160 daN
Torque	4,000 daN
Tipping load, straight	3,167 kg / 3,550 kg*
Tipping load, articulated	2,769 kg / 3,100 kg*
Lifting capacity at ground level	4,650 daN
Operating weight	4,550 kg / 4,850 kg*

Specifications

Differing data for use of pallet forks (500 mm distance to center of gravity)*

Static tipping load, straight and articulated	2,290 kg / 2,540 kg*
Lifting capacity	2,845 daN
Payload 80% even surface**	1,832 kg / 2,032 kg*
Payload 60% uneven surface***	1,374 kg / 1,524 kg*

Sound level

Average sound power level $L_{WA}^{(1)}$	100.0 dB(A)
Guaranteed sound power level $L_{WA}^{(2)}$	101.0 dB(A)
Sound pressure level $L_p^{(3)}$	79.0 dB(A)
Vibration values hand/arm/whole body vibration ⁽⁴⁾	< 2.5/0.5 m/s²

*Travel with load only permitted close to the ground. **According to ISO 8313 and EN 474-3. ***According to ISO 14396, EU RL97/68/EC. (1) According to 2000/14/EG & appendixes. (2) According to 2000/14/EG & appendixes. (3) According to ISO 6396. (4) According to ISO 8041.

Important Information on Shovel Size / Shovel Contents:

The details contained in this brochure relate solely to the weycor shovels referred to in the respective data sheet, with the associated technical parameters and configurations on which the respective CE approval for the device is based. The volume of the specific usable shovel depends on the material-specific bulk weights (t/m³) of the shovel contents, which you can take as approximations from the data sheet's TABLE OF SPECIFIC WEIGHTS IN t/m³. Regardless of this, neither the wheel loader's permissible working weight nor its permissible tipping loads may be exceeded. If the wheel loader is equipped with shovels that are not manufactured and licenced by Atlas Weyhausen GmbH, the buyer and / or the operator is solely responsible for compliance with the relevant statutory regulations and licensing requirements – particularly those relating to road-traffic and road-traffic-licensing law.

*While using the optional additional counterweight.
All technical information refers exclusively to the standard device.

DETAILS THAT MAKE AN IMPRESSION

It is demanding to meet the new legal requirements for exhaust emissions. The challenge is to create also tangible benefits for our customers. We are proud to have achieved both in the development of the current wheel loader generation: more power - less consumption, plus a number of others innovations that really make a difference on tough construction sites.

State of the art kinematics

weycor Z-kinematics is characterised by high frictional forces and excellent lifting heights. The very good parallel guide provides the optimal prerequisites for using pallet forks. When the hoist is lowered with the shovel, the shovel returns automatically to the digging position. The boom that is tapered towards the top provides the best possible view of the attachment and working area at all times, even under difficult operating conditions.

Hydraulic quick-change attachment

By allowing you to change the wheel loader's attachments in a few seconds, it turns the vehicle into an all-rounder.

Articulated-pendulum joint

In weycor wheel loaders, we use robust, low-maintenance articulated-swivel joints almost exclusively in conjunction with rigid axes. With an oscillation of $\pm 12^\circ$ in the rear carriage and an articulation angle of 40° , these provide outstanding cross-country mobility, protect the ground and offer extreme manoeuvrability. With their low centre of gravity, weycor wheel loaders have a high tilt stability even under extreme conditions.

Easy maintenance

Low-maintenance and quick, easy servicing is achieved by central, consolidated, easy-to-reach service points.

Comfortable cabin

In addition to the excellent circumferential visibility in the wheel loader, its clearly arranged controls and its ergonomic design.

Powerful drive unit

weycor wheel loaders are equipped with state-of-the-art engines which combine high power reserves for challenging operations with up-to-date low emission values.

Inching Pedal

As the only manufacturer, our wheel loaders have a separate inching pedal as standard. This prevents the possibility of moving against the operating brake, in contrast to the combination of a brake/inch pedal. A generously proportioned inching range facilitates precise distribution of shearing and lifting forces. The result: less wear and lower fuel consumption.

Spring-loaded brake

The spring-loaded or negative brake in weycor wheel loaders is a closed brake system (oil bath multiple-disc brake) which holds the wheel loader securely in position on a slope when the brake or inch function is activated and automatically locks all four wheels when the engine is at a standstill. The multiple-disc brake runs in the oil bath and is particularly low-maintenance and low-wearing as a result.

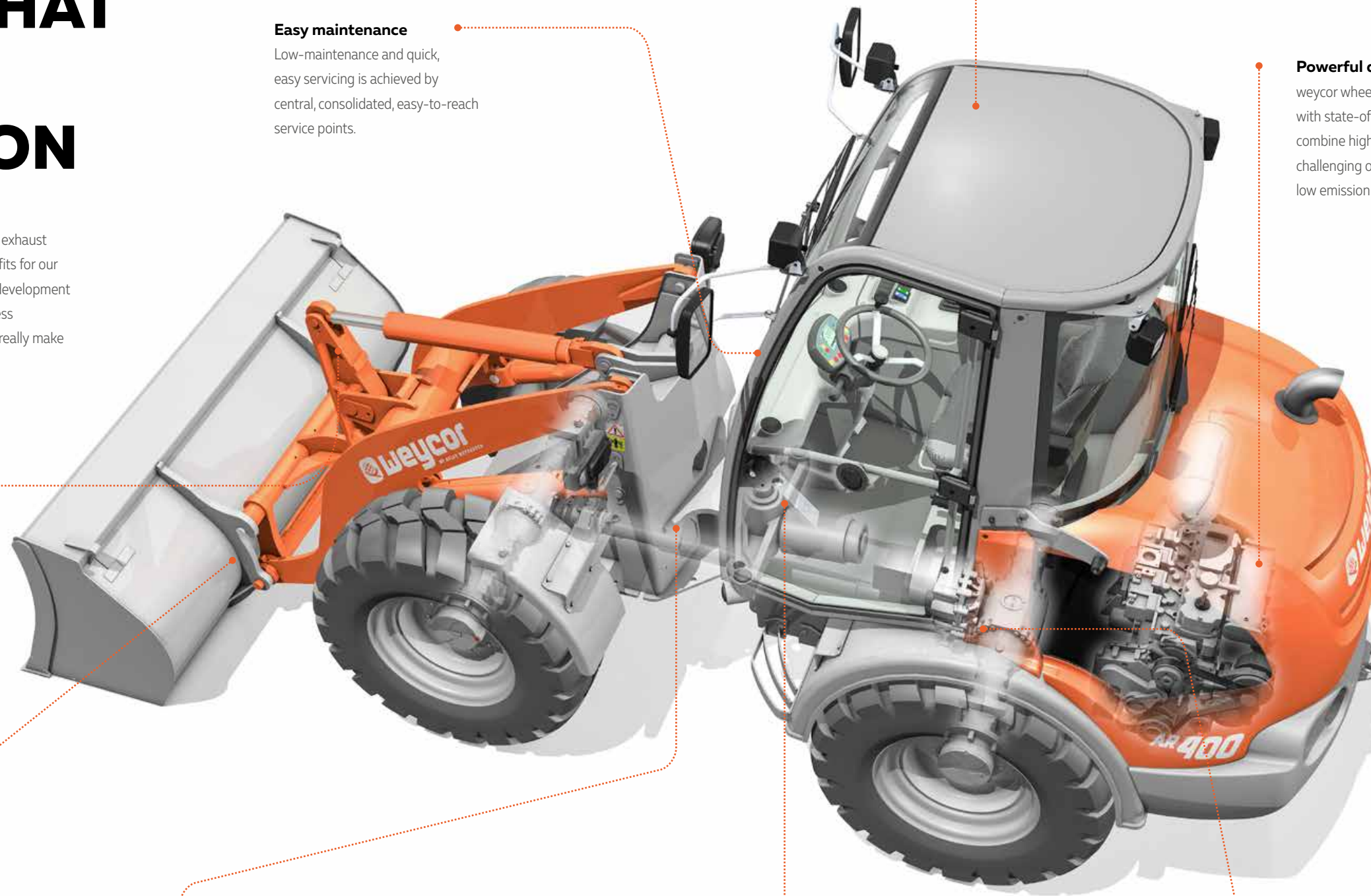

INNOVATIVE ENGINE TECHNOLOGY

4TNV86CHT – intelligent efficient:

We are convinced of modern diesel engine technology. These can also be found in the AR 400: for example the electronic motor control with an intelligent connection to the drive management. This ensures the best engine performance with low fuel consumption.



Yanmar engine technology: 4TNV86CHT

The Yanmar 4TNV86CHT engine meets the required NOx and PM limits in accordance with the world's most stringent emission regulations of EU Stage 5. The engine is characterized by a compact design and provides high torque at low speed. The intelligent control system optimizes the response characteristics of the engine and reduces fuel consumption and noise emissions. It enables accurate maintenance and electronic diagnostics and can communicate with any CAN interface.

Mighty performance

46 kW at a maximum of 2,300 rpm

Compliance with emission standards

EU Stage 5 - DOC + DPF



TECHNICAL DATA

Engine	
Model	Yanmar 4TNV86CHT
Design	water-/intercooled
Output	46 kW (61.5 HP) at 2,300 rpm
Max. torque	198 Nm at 1,690 rpm
Cubic capacity	2,091 cm ³
Number of cylinders	4 in line

Electrical system	
Operating voltage	12 V
Battery	12 V / 100 Ah
Generator	12 V / 55 A
Starter	12 V / 2.3 kW

Drive
Output-regulated hydrostatic drive with pressure cut off and closed circuit acting on all 4 wheels. Speed with standard tires: Operating speed range 0–6.5 km/h Road speed range 0–20 km/h 1st and 2nd hydraulic gear can be engaged under load, forward/backward travel also. Forward/backward travel, speed ranges and off-position operational via weycor joystick. Drive operated by accelerator and separate inching pedal for best distribution of the hydraulic power for thrust and lifting forces.

Brakes
Standard brake: Multi-disc brake in oil bath acting on rear axle. Supplementary brake functions via inching pedal and hydrostatic drive acting on all 4 wheels. Parking brake: Parking brake as springloaded brake acting on rear axle. In case of standstill of engine the spring-loaded brake is automatically reactivated.

Axles
Rigid axles with planetary reduction gears in wheel hubs, connecting electrically 100%- differential lock in front and rear axle.

Steering
Fully hydraulic center pivot steering Front and rear wheels follow the same track Steering angle of 40° to each side, ±12° angular movement at rear of vehicle Operating pressure of steering hydraulics 175 bar Emergency steering function

Tires <small>(Special tires upon request)</small>
Standard: 12.5-18 MPT – Multi-purpose tires for sand and gravel surfaces, woodland, roads and paths Special tires: 12.5-20 MPT – Multi-purpose tires for sand and gravel surfaces, woodland, roads and paths 405/70 R18 SPT9 – Construction machine tires for clay, sand, gravel, asphalt, roads, gardening and landscaping 400/70 R20 XMCL – Wheel loader tires for clay, sand, gravel, fields and greenland, fortified roads 335/80 R20 EM – Construction machine tires for clay, sand, gravel, asphalt, roads, gardening and landscaping 15.5/55 R18 – Construction machine tires for clay, sand, gravel, broken stone and fortified roads

Hydraulic system
Gear pump for loading and steering hydraulics Priority valve favoring steering hydraulics 3rd section Loading hydraulic activated by weycor joystick, including float position Operating pressure 235 bar, Delivery of pump 57.5 l/min

Fuel/oil capacities	
Diesel	61.5 Liter
Hydraulic oil	41 Liter
Engine oil	7.4 Liter
Front axle	4.6 Liter
Rear axle	4.4 Liter
Gear oil	0.9 Liter
Cooling liquid	8.5 Liter

Loading equipment	
Powerful and solid Z-kinematics with high tear out force Hydraulic quick change device Activation of all functions by weycor joystick Parallel movement while using pallet forks Automatic shovel return to excavation position Automatic center position Locking device acc. to German StVZO for road travel	
Lifting	5.0 s
Lowering	3.6 s
Tipping	1.5 s

Equipment – Series	
Rear driving mirrors, foldable Heatable rear screen Access left side, right window to open can be fastened Activation of all functions by weycor joystick Control lights for speed range, forward/backward travel Lights acc. to German StVZO for road travel Individually adjustable driver's seat Hot water heating with heat exchange and 3-stage-fan Front windscreen ventilation, variable output Sound absorbing ROPS cab Windscreen wipe and wash unit in front and rear Sun visor, coat hook, ceiling lamp, stow facility Heat protection glazing with largetinted screens	
Control lights for engine oil pressure, overheating, hydraulic oil temperature, battery power, parking brake and air filter Central dashboard with indicators for preheating, engine temperature, fuel, working hour meter	

Equipment – Option	
Main battery switch Special paintings and oils FOPS roof Level II Load check valve for lifting and working cylinders Trailer coupling Anti-theft-device with code stick Load rupture protection for lifting and working cylinders Radio Warning beacon Heavy rear weight Extended lifting device, measure C2 +150 mm Valve protection for rims	

TECHNICAL DATA

	AR 400 with standard shovel	AR 400 with pallet forks
A	5,250 mm	5,540 mm
B	2,475 mm	2,475 mm
B1	1,765 mm	1,765 mm
C	3,930 mm	3,380 mm
C1	3,130 mm	2,925 mm
C2	2,475 mm	1,315 mm
D	85 mm	70 mm
E	670 mm	430 mm
E1	-	1,200 mm
E2	-	750 mm
F	440 mm	440 mm
G	2,000 mm	2,000 mm
H	1,785 mm	1,785 mm
I	1,850 mm	1,030 mm
R	1,840 mm	1,840 mm
R1	3,690 mm	3,690 mm

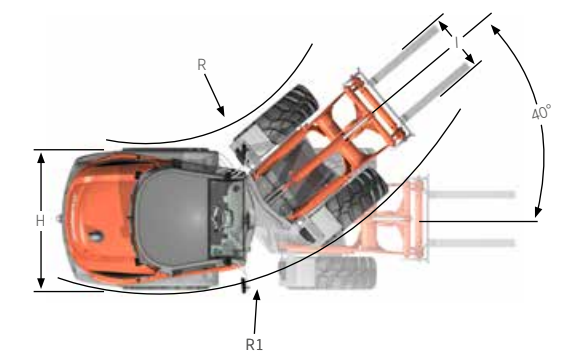
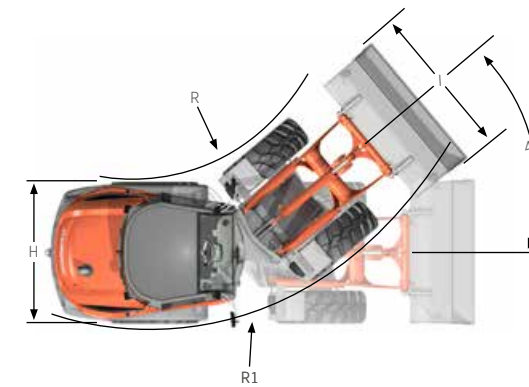
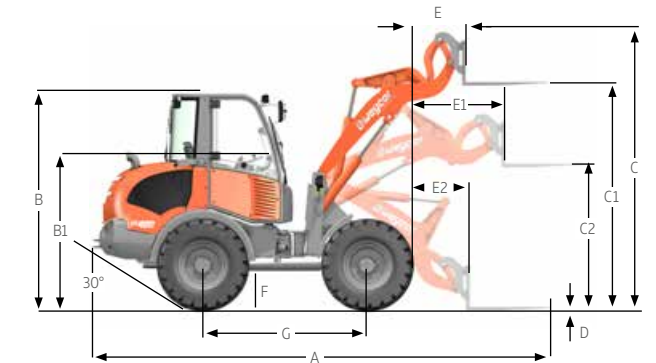
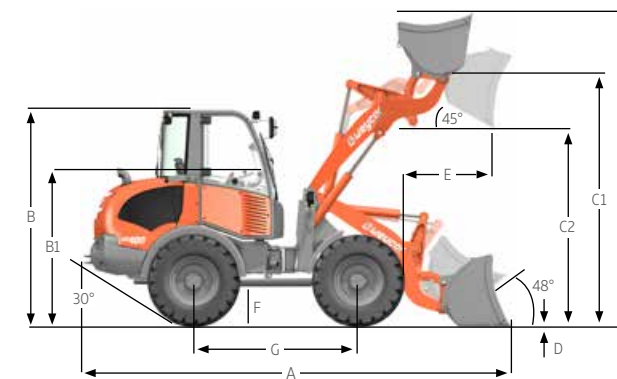

With standard shovel

With pallet forks

Specific gravity for material handling weight (t/m³)

Construction		Industry		Landscaping, Agriculture			
Concrete	1.9	Sand (watery)	2.1	Ember	0.7	Agricultural crop	0.7
Soil (dry)	1.5	Sandstone	2.4	Brown coal briquette	0.8	Grain	0.6
Soil (watery)	2.0	Shale	2.2	Ferrous product	7.8	Hay	0.3
Rock (fill)	2.4	Sediment	2.1	Iron ore	2.3	Potash	1.1
Granite	1.8	Crushed stone	1.5	Cullet	1.9	Compost	1.0
Limestone	1.6	De-icing salt	1.3	Gas coke	0.4	Flour	0.5
Gravel (dry)	1.9	Clay	1.6	Timber	0.8	Clay (watery)	2.3
Gravel (watery)	2.1	Cement	1.7	Mineral coal	1.2	Phosphate fertiliser	2.2
Loam	1.7	Clinker (stacked)	1.8	Paper	0.9	Turf (watery)	1.1
Plaster	2.2			Slag	1.0	Turf (dry)	0.4
Sand (dry)	1.9			Slag concrete	2.7	Mineral fertiliser	1.0



You can find our current product range and more exciting details at: www.products.weycor.de or www.weycor.de

weycor is a brand of ATLAS WEYHAUSEN GMBH.

ATLAS WEYHAUSEN GMBH · D - 27793 Wildeshausen
Phone +49 (0) 44 31 - 98 10 · info@weycor.de · www.weycor.de



Under our policy of continuous improvement, we reserve the right to change specifications and design without prior notice, errors expected. The technical data refer only to the standard version, illustrations do not necessarily show the standard version of the machine. Not all products are available in all markets.